

Assembly
and
Operation
of the



SSB TRANSCEIVER
MODEL HW-101



7W101
#12431
C-12

HEATH COMPANY
BENTON HARBOR, MICHIGAN 49022

ALIGNMENT

The coils and transformers in your Transceiver have been preset at the factory. Only minor readjustments should be necessary during the following alignment procedure.

The following equipment is necessary for alignment of the Transceiver.

1. A test meter, such as an 11 megohm input voltmeter. (Vacuum tube and solid-state models are found in the Heath catalog.) A 20,000 ohm-per-volt VOM may be used, but will load the circuits to a greater extent.
2. A 50 Ω nonreactive dummy load that is capable of 100 watts dissipation, such as the Heathkit Cantenna. Do not use light bulbs for a dummy load as they present an impedance which varies with power and frequency.
3. A receiver capable of receiving WWV at 2.5, 5, 10, or 15 MHz. If this type of receiver is not available, a receiver tunable to a standard broadcast station which is operating at an even multiple of 100 kHz (such as 600 kHz, 1000 kHz, etc.) can be used.
4. An accurate 100 kHz standard oscillator may be used for the alignment of tuned circuits. **DO NOT** use such an oscillator to adjust the Transceiver crystal calibrator. For this purpose refer to the "Crystal Calibrator Alignment" section of this Manual.

For the alignment of the transmitter section it is recommended that you use an oscilloscope, such as the Heathkit Signal Monitor Scope to observe the output RF envelope.

WARNING: Do not place the Transceiver in the transmit mode of operation until directed to do so or the Transceiver may be seriously damaged.

(✓) Connect a 50 Ω dummy load, capable of 100 watts dissipation, to the ANTENNA jack on the rear of the chassis. CAUTION: Do not use light bulbs as a dummy load.

(✓) Be sure an 8 Ω speaker is connected to the 8 Ω jack on the rear of the chassis.

(✓) Preset the CAL XTAL trimmer so its notch is towards the 100 kHz crystal as shown in Figure 1-2 (fold-out from Page 100).

(✓) Preset the front panel controls as follows:

DRIVER PRESELECTOR – 12 o'clock position.

MIC/CW LEVEL – fully counterclockwise.

MODE – LSB.

BAND – 3.5.

MAIN TUNING Dial (VFO) – 200.

FUNCTION – PTT.

RF GAIN – fully clockwise.

METER – ALC.

AF GAIN – 9 o'clock position.

S METER ADJUSTMENT

(✓) Adjust the ZERO ADJ control (on the right side of the chassis) for a zero indication on the meter with the antenna disconnected and the RF GAIN control at the full clockwise position.

RECEIVER ALIGNMENT

- (✓) Set the test meter switches so the meter will indicate a negative (-) dc voltage.
- (✓) Connect the common lead of the test meter (11 megohm input voltmeter) to the chassis and the other lead to the circuit board foil at TP (Figure 1-2) on the screened side of the bandpass circuit board near tube V19. If your meter reads 0 at TP, contact instead the adjacent lead of the 100 k Ω (brown-black-yellow) resistor. A reading of -.82 V or higher is normal.

The heterodyne oscillator output will be checked at each position of the BAND switch in the following steps. If necessary, the heterodyne oscillator coils will be adjusted to obtain a preliminary output voltage reading. Final adjustment will be made later. Carefully insert the slim end of the alignment tool fully into each slug before turning, to avoid core breakage.

NOTE: The heterodyne oscillator crystals that are supplied with the Transceiver provide coverage from 3.5 to 4.0 MHz, 7.0 to 7.3 MHz, 14.0 to 14.5 MHz, 21.0 to 21.5 MHz, and 28.0 to 30.0 MHz. As the driver grid and driver plate coils must be sequence-tuned (because of their series-parallel arrangement) other heterodyne crystals for out-of-band operation could introduce a wide variety of possible tuning conditions. Therefore, we recommend that you do not use crystals of frequencies other than those supplied.

It is not abnormal to receive "birdies" in the vicinity of 3740 kHz and 21,200 kHz.

- (✓) With the BAND switch at 3.5, the test meter should indicate about -0.5 to -2 volts dc. If necessary, adjust coil 3.5 (near tube V11 on the top side of the RF driver circuit board) to bring the voltage into this range. NOTE: When adjusting this coil in one direction, the oscillator output voltage will change rapidly; when adjusting the coil in the opposite direction from the peak, the output voltage will change slowly. Adjust the coil in the direction that gives the slower change in output voltage.

- (✓) Similarly, check the heterodyne oscillator output voltage at all positions of the BAND switch. If necessary, adjust the correct heterodyne oscillator coil for any BAND switch position that does not give an indication of about -0.5 to -2 volts dc on the test meter. The heterodyne oscillator coils for bands 3.5, 14, and 28.5 are marked, and adjusted at the top side of the RF driver circuit board; the coils for the other bands are marked on the shield cover, and are adjusted from the bottom of the chassis.

- (✓) Turn both VFO trimmer capacitor screws (through two holes on the left side of the VFO chassis) clockwise until just snug. Then turn each capacitor screw counterclockwise one-quarter turn.

- (✓) Set the FUNCTION switch to CAL and the BAND switch to 3.5; then turn the MAIN TUNING dial back and forth around 400 to get a calibrator signal. Check for the calibrate signal by turning the FUNCTION switch to VOX and back to CAL; the signal should stop and then start again and should peak with the DRIVER PRESELECTOR.

- (✓) Reset the DRIVER PRESELECTOR to the 12 o'clock position.

- (✓) Disconnect the test meter leads from the Transceiver.

The S Meter will be used as an output indicator during the remaining alignment of the Transceiver and the 100 kHz calibrator will be used as a signal source.

When adjusting the transformers in the following steps, use the large end of the tuning tool for the top core. Use the long, thin end (which is inserted through the top core) for the bottom core.

CAUTION: The 6.8 MHz trap coil is sealed, and should not be turned.

NOTE: It should not be necessary to turn the cores of transformers T201 and T103 more than two turns.

- (✓) Adjust transformer T201 for maximum volume.

- (✓) Adjust the top and bottom slugs of transformer T102 for a maximum volume or S Meter indication.
- (✓) Adjust the slug of transformer T103 for a maximum S Meter indication.
- (✓) Repeat the adjustments of transformers T201, T102, and T103 for a maximum S Meter indication.

VFO ALIGNMENT

- (✓) Make sure the Transceiver has been warmed up for at least 30 minutes before making the following adjustments.

NOTE: Refer to Reading the Dial on Page 139.

- (✓) Find the CAL signal within approximately 25 kHz of 3900 kHz (400 on the dial). A general coverage receiver tuned to 5100 kHz will aid in identifying the VFO signal. If you are receiving a CAL signal, it will cease when the Function switch is set at VOX.
- (✓) Find the CAL signal near 4000 kHz. Then carefully turn the dial to its counterclockwise stop. Hold the VFO knob with one hand and, with the other hand, slip the circular dial until the end of the scale marked "Stop" coincides with the hairline at the "500" end. See Detail 8-9A on Page 78.
- (✓) Again tune in the 4000 kHz CAL signal.
- (✓) Carefully tune off the 4000 kHz CAL signal to the side toward the 500 dial reading. Then adjust the VFO COIL to move the CAL signal to your listening frequency. By alternately moving your listening frequency and then adjusting the VFO COIL, you can "walk" the CAL signal in the desired direction until it coincides with the 500 dial reading.
- (✓) Turn the dial to the vicinity of 0 and identify the 3500 kHz CAL signal. Move this signal so that it coincides with the 0 dial reading by adjusting both VFO TRIMMERS.

- (✓) As the two preceding adjustments interact to some extent, repeat them until the 3500 kHz and 4000 kHz CAL signals coincide respectively with the 0 and 500 marks on the dial.

NOTE: The VFO signal may be tuned in on a general coverage receiver at 5000 kHz for the "500" dial setting, and at 5500 kHz for the "0" dial setting.

DRIVER GRID AND PLATE COILS

The driver grid and driver plate coils will be adjusted in the following steps. The coil locations are marked on the shield cover on the bottom of the chassis. These coils must be adjusted in the proper sequence as follows:

- (✓) Set the MAIN TUNING dial to 200, and the DRIVER PRESELECTOR to the 12 o'clock position.
- (✓) Adjust driver grid coil 3.5 and driver plate coil 3.5 for a maximum S Meter indication. The S Meter will move slowly during the adjustment of these two coils.
- (✓) Change the setting of the front panel controls as follows:
 - DRIVER PRESELECTOR – 29.2 position. See the inset drawing on Figure 1-3 (fold-out from Page 106).
 - BAND – 29.0.
 - MAIN TUNING dial (VFO) – 200 kHz.
- (✓) Turn the MAIN TUNING dial back and forth around 29.2 MHz to get the loudest signal. Check for the calibrate signal by turning the DRIVER PRESELECTOR to make sure there is a variation in volume. Return the DRIVER PRESELECTOR to the 29.2 position.
- (✓) Adjust driver grid coil 29 and driver plate coil 29 for a maximum S Meter indication.



- (✓) Change the setting of the front panel controls as follows:

DRIVER PRESELECTOR – 21.2 position. See the inset drawing on Figure 1-3.

BAND – 21.0

MAIN TUNING dial – 200 kHz

NOTE: In the following step, the CAL signal and the VFO harmonic will be found very close together, showing that the VFO is correctly calibrated. The CAL signal is much stronger and can be identified by switching the FUNCTION switch between CAL and VOX.

- (✓) Turn the MAIN TUNING dial back and forth around 21.2 MHz for the loudest signal.

- (✓) Adjust driver grid coil 21 and driver plate coil 21 for a maximum S Meter indication.

- (✓) Turn the BAND switch to 14.0, the MAIN TUNING dial to 200 kHz, and the DRIVER PRESELECTOR to the 14.2 position.

- (✓) Tune the MAIN TUNING dial for the loudest signal and check for the calibrate signal.

- (✓) Adjust driver grid coil 14 and driver plate coil 14 for a maximum S Meter indication.

- (✓) Set the BAND switch at 7.0 and the MAIN TUNING dial at 200 kHz.

- (✓) Tune the MAIN TUNING dial for the loudest signal.

- (✓) Adjust driver grid coil 7 and driver plate coil 7 for a maximum S Meter indication.

- () Set the FUNCTION switch to PTT.

Proper receiver operation will be indicated by minimum calibrator signals of S9 +20 dB at 3700 kHz and decreasing to S3 at 29.2 MHz.

TRANSMITTER ALIGNMENT

See the "Reading the Meter" section on Page 139 before making any more adjustments.

CAUTION: The coil cover MUST be in place for proper transmitter operation.

- (✓) Connect a push-to-talk microphone to the MIC connector on the front panel.

- (✓) If a Monitor Scope is available, connect it between the ANTENNA jack and the dummy load. Be sure the dummy load is capable of 100 watts dissipation. Do not use light bulbs for a dummy load, as damage may result.

- (✓) Turn the adjusting screw of the NEUTRALIZING CAPACITOR (through the hole in the front of the RF Cage) clockwise until resistance is felt. Then turn the screw counterclockwise on full turn.

- (✓) Set the front panel controls as follows:

DRIVER PRESELECTOR – 12 o'clock position.

MIC/CW LEVEL – fully counterclockwise.

FINAL (round knob) – to 10 o'clock.

FINAL (lever knob) – to 4 o'clock.

MODE – LSB.

BAND – 3.5.

MAIN TUNING dial – 200 kHz.

FUNCTION – PTT.

METER – PLATE.

- (✓) Press the microphone button and turn the BIAS control (on the right side) of the Transceiver to set the meter needle at the ▼ mark (above the Figure 3) on the meter scale. This sets the resting cathode current. Do not press the microphone button more than a few seconds at one time until this resting cathode current has been properly adjusted.

- (✓) Set the METER switch to REL PWR and press the microphone button. The meter needle should show 0.

- (✓) Set the MODE switch at the TUNE position and slowly turn the MIC/CW LEVEL control in a clockwise direction until there is an indication of RF output on the meter or oscilloscope.
- (✓) Adjust the DRIVER PRESELECTOR control for maximum RF output.
- (✓) Adjust the FINAL tune (round knob) control for maximum RF output.
- (✓) Adjust the MIC/CW LEVEL control for an RF output of not more than S-3.
- (✓) Adjust transformer T1 for maximum RF output. It should not be necessary to adjust this transformer more than one complete turn.
- (✓) Again reduce the MIC/CW LEVEL for a low meter indication and again adjust Transformer T1 for maximum output.
- (✓) Turn the MIC/CW LEVEL control and DRIVER PRESELECTOR control to obtain maximum RF output on the meter or oscilloscope.
- (✓) Place the MODE switch at LSB. Leave the MIC/CW LEVEL control at its present setting.

NOTE: The long step following accomplishes the preliminary neutralizing adjustment. Read this step thoroughly and visualize what the step requires. When you perform the adjustments, have the Transceiver at full power output for the minimum time necessary. Then place the MODE switch at LSB and let the final stage tubes cool for at least 30 seconds before turning the Transceiver on again.

- (✓) Set the METER switch to the PLATE position.
- (✓) Turn the MODE switch to TUNE.
- (✓) Adjust the FINAL tune control for minimum plate current. Set the METER switch to REL PWR or observe the output on a monitor scope. Then adjust the FINAL tune control for maximum meter indication and note the position of the control. If maximum relative power and minimum plate current do not occur at the same point of tuning, turn the neutralizing capacitor a small amount. Check the position of the FINAL tune control at minimum plate current and also at the maximum relative power indication. The neutralizing capacitor should be adjusted a small amount at a time until minimum plate current and maximum relative power occur at the same point of tuning the FINAL tune control.
- (✓) Turn the MIC/CW LEVEL control fully counterclockwise.
- (✓) Turn the MODE switch to LSB, push the microphone button, and adjust the CARRIER NULL control for minimum RF output. Note that the smaller end of the nut starter fits the shaft of this control.
- (✓) Adjust the CARRIER NULL capacitor for minimum RF output.
- (✓) Turn the MODE switch to USB and, with the microphone button pressed in, adjust the CARRIER NULL control for minimum RF output.
- (✓) Adjust the CARRIER NULL capacitor for minimum RF output.
- (✓) Repeat the adjustments of the CARRIER NULL control, and the CARRIER NULL capacitor until the RF output or null reading is about the same on both the LSB and USB positions of the MODE switch. A receiver with an S Meter can be used for the carrier null indication, and it is usually more sensitive for this purpose.

NOTE: An 11 MΩ input voltmeter with an RF probe can also be used at this time, if one is available, to obtain additional accuracy in the carrier null adjustments. To null the carrier in this manner, measure the RF voltage with the RF probe at lug 1 (the center conductor) of the ANTENNA connector. Then adjust the CARRIER NULL control and CARRIER NULL capacitor for the lowest RF voltage, which should be 1/4 volt or less.

- (✓) Turn the MODE switch to TUNE and set the METER switch at the REL PWR position.
- (✓) Adjust the DRIVER PRESELECTOR and the FINAL TUNE and LOAD controls for maximum output. Then adjust the MIC/CW LEVEL control for a reading between 3 and 9 on the panel meter.
- (✓) Adjust heterodyne oscillator coil 3.5 for maximum output, with the tuning on the "slow" side of the peak.
- (✓) Repeat the two preceding steps for each position of the BAND switch, except adjust the HET OSC coil that has the same number as the BAND switch position.

- (✓) Set the BAND switch at 21.0 and turn the MAIN TUNING dial to read 21.2 MHz.
- (✓) Adjust the DRIVER PRESELECTOR control and the FINAL TUNE and LOAD controls for maximum RF output; then turn the DRIVER PRESELECTOR control back and forth to see if this produces a smooth peaking in RF output.
- (✓) If turning the DRIVER PRESELECTOR control causes ragged changes in the RF output, readjust the position of, or bend, the free end of the driver neutralizing wire to produce a smooth peaking in RF output (this is the white, insulated wire inserted in hole W of the RF Driver circuit board, as shown in Figure 1-2, fold-out from Page 100).
- (✓) Set the BAND switch to 14.0 MHz and the MAIN TUNING dial to 14.2 MHz. As you did before on the 3.5 MHz band, peak the DRIVER PRESELECTOR and FINAL controls for maximum output. Compare the control settings at which maximum relative power output and minimum plate current occur. Again adjust the neutralizing capacitor until these points coincide. This completes the neutralization.
- (✓) Rezero the ALC position of the S Meter while receiving, with the BAND switch at 29.5. Then check to be sure the meter reads zero in each BAND switch position. If the S Meter does not read zero on any band, readjust the heterodyne oscillator coil for that band, as directed in previous steps.
- NOTE: The S Meter may rest below zero while you are transmitting. This condition is normal.

CRYSTAL CALIBRATOR ALIGNMENT

In the following steps, the 100 kHz crystal calibrator signal is adjusted by "zero beating" it against the accurate signal from WWV on another receiver, or against the signal from a standard broadcast station that is on a multiple of 100 kHz.

Zero beat will occur when a harmonic of the 100 kHz crystal calibrator signal corresponds to the frequency of the station tuned in on the external receiver. As zero beat is approached, a tone will be heard that decreases in frequency until it stops completely at the zero beat point; then the tone begins to increase again as the dial is turned.

If the external receiver has an S Meter, accurate alignment can be achieved by observing the S Meter as zero beat is approached. When you tune close to zero beat, the S Meter will start to pulsate. The closer you approach zero beat, the slower the pulsations will become. At zero beat the pulsations will stop. Use a "fast" AVC position, if one is available.

IMPORTANT: For greatest accuracy, be sure to adjust the crystal calibrator as close to zero beat as possible. A 20 Hz error at the 100 kHz calibrator frequency, for example, would cause a 740 Hz error at 3.7 MHz (where the 37th harmonic of 100 kHz would be used for dial calibration purposes; $100 \text{ kHz} \times 37 = 3.7 \text{ MHz}$; $20 \text{ Hz} \times 37 = 740 \text{ Hz}$). In view of this, it is recommended that the crystal calibrator be adjusted to the 15 MHz signal of station WWV.

- (✓) Connect a random length of wire from the antenna connection of the external receiver to the ANTENNA connection of the Transceiver. If necessary, use one of the phono plugs furnished. It can be removed later.
- (✓) Set the Transceiver controls as follows:
- FUNCTION switch – CAL.
- AF GAIN control – full counterclockwise.
- MODE switch – CW, LSB, or USB.
- (✓) Tune the external receiver to WWV, or a standard broadcast station transmitting at a frequency which is a multiple of 100 kHz.
- (✓) Carefully adjust the CAL XTAL trimmer capacitor (on the bandpass circuit board) for a "zero beat" in the external receiver. When WWV is tuned in, the period when no tone modulation is present allows the zero beat to be more easily heard.
- (✓) Switch the Transceiver FUNCTION switch to VOX and return it to CAL to be sure the external receiver S Meter stays steady, thus insuring a true zero beat.
- (✓) Remove the external receiver antenna wire from the ANTENNA jack on the Transceiver.

NOTE: To make sure it is heard on each band, a high content of harmonic energy is needed in the 100 kHz calibrate signal. Because of this, some spurious signals may also appear when tuning across some segments of the bands. The desired 100 kHz calibrate signals are easily identified by their greater signal strength. Also, the proper harmonics may be peaked by the DRIVER PRESELECTOR.

VFO SHIFTER ADJUSTMENT

- (✓) Adjust the MAIN TUNING dial to 200 kHz and the BAND switch to 3.5.
- (✓) Set the FUNCTION switch to CAL.
- (✓) Turn the MODE switch to USB.

(✓) Carefully zero beat the calibrator signal. Use the MAIN TUNING dial and peak the DRIVER PRESELECTOR control.

(✓) Set the MODE switch to LSB. Be careful not to touch the MAIN TUNING dial. Note that the calibrator signal may or may not be exactly at zero beat in the LSB position.

(✓) Turn the SHIFT ADJUST on the VFO for an exact zero beat in the LSB mode. See Figure 1-2 (fold-out from Page 100).

(✓) Recheck the zero beat in the USB mode to be certain of the adjustment. Repeat the procedure, if necessary.

DIAL CALIBRATION

NOTE: The instructions in this section use the 0 mark on the MAIN TUNING dial as the dial calibration point. The same instructions also apply at any 100 kHz marking.

(✓) Set the BAND switch at 3.5 and the MAIN TUNING dial at 0 kHz. Zero beat the crystal calibrator signal at 3.5 MHz. If the 0 mark on the dial is not behind the index line in the dial window, proceed with the following steps.

(✓) Note which way you turn the dial, and move the 0 on the dial behind the index mark in the dial window.

(✓) Push the ZERO SET button to lock the dial in place, and turn the dial knob in the opposite direction to bring the calibrate signal into zero beat at the 0 mark on the dial. Release the ZERO SET button.

(✓) Check the accuracy of the adjustment and repeat the above steps, if necessary.

This completes the alignment of your Transceiver.

NOTE: To verify that the VFO is operating on the proper frequency, tune in a signal of known frequency, such as time station CHU on 7335 kHz. This station is operated by the Dominion Observatory, Canada.

OPERATION

NOTE: YOU MUST HAVE AN AMATEUR RADIO OPERATOR AND A STATION LICENSE BEFORE PLACING THE TRANSMITTER SECTION OF THE TRANSCEIVER ON THE AIR. INFORMATION ABOUT LICENSING AND AMATEUR FREQUENCY ALLOCATIONS IN THE UNITED STATES IS AVAILABLE FROM PUBLICATIONS OF THE FEDERAL COMMUNICATIONS COMMISSION OR THE AMERICAN RADIO RELAY LEAGUE, 225 West Main Street, Newington, Connecticut 06111.

Operation of the Transceiver has been simplified as much as possible to permit rapid adjustment by the operator. Once

the initial settings have been made, it should not be necessary to readjust most of the controls. Read the following information carefully. Good operating techniques will provide good clean signals and long trouble-free life of the Transceiver.

CAUTION: Be sure a 50 to 75 Ω nonreactive load is connected to the ANTENNA jack before operating the Transceiver. This load can be an antenna, a dummy load, or a properly adjusted linear amplifier. (See the "Installation" section of the Manual on Page 131).

READING THE METER

Figure 1-18 illustrates the meter face. The figures 0 to 9 under the left half of the arc are read as "S units," and the figures above the right half of the arc are read as "decibels over S9." The \blacktriangledown mark is the point to which the cathode current is adjusted.

The ALC (automatic level control) position of the meter switch results in "S Meter" action during reception, and indicates the relative ALC voltage during transmission. No S Meter action can be secured with the meter switch in the REL PWR or PLATE positions.

The REL PWR position causes the meter to read an uncalibrated amount of rectified output power. This position is useful for determining the tuning conditions for maximum output power.

The PLATE position of the switch causes the meter to read cathode current to the final stages. There are six numbers on the S Meter (in addition to 0). When reading cathode current, each number represents 50 milliamperes. Thus:

<u>Scale Number</u>	<u>Milliamperes of Cathode Current</u>
0	0
3	50
6	100
9	150
20	200
40	250
60	300

READING THE DIAL

The tuning dial is calibrated in divisions from 0 to 500. Each represents 5 kHz. The dial reading (in kHz) is added to the Band switch setting (in MHz) to determine the frequency to which the Transceiver is tuned. For example:

Band switch	14. MHz
Dial reading	235 kHz
Frequency	<hr/> 14.235 MHz



RECEIVER SECTION

1. Set the MODE switch to either LSB or USB.
2. Turn the RF GAIN control to its fully clockwise position.
3. Turn the AF GAIN knob and allow the Transceiver to warm up.
4. Adjust the AF GAIN control clockwise until some receiver noise is heard.
5. Set the FILTER switch to SSB or CW, as appropriate.

If an extremely strong station overloads the receiver front end, leave the AF GAIN control set for comfortable listening; then adjust the receiver level with the RF GAIN control. This will keep the front end from overloading and masking weaker signals.

The S Meter will move with adjustment of the RF GAIN control, but will still read correctly with the RF GAIN set at less than maximum (if the received signal level is high

enough to register on the S Meter). For example, if the RF GAIN control is set for no-signal meter reading of S5, and the meter registers S9 with a signal, then the received signal is S9.

6. The Transceiver is now ready to receive. Turn the BAND switch to select the desired 500 kHz band segment. The frequency of the tuned signal is determined by adding together the settings of the BAND switch, and the circular dial.
7. Peak the DRIVER PRESELECTOR for maximum signal.
8. Set the FUNCTION switch to CAL. Rotate the MAIN TUNING dial (VFO) to the nearest 100 kHz point on the circular dial.
9. Adjust the MAIN TUNING dial until the calibrate signal is at zero beat. (To be sure that the correct calibrate signal is being used, check the DRIVER PRESELECTOR tuning. If the signal strength varies, you are tuned to the correct calibrator signal.)

TRANSMITTER SECTION

WARNING: Portions of each band are for CW operation only. DO NOT operate the Transceiver with voice modulation in any portion of a CW subband. To do so (in the U.S.A.) will invite disciplinary action by the Federal Communications Commission.

Make SURE your dial calibration is correct, since it is possible for the circular dial to be 100 kHz off frequency. For example, your dial could read 14.3 MHz but your actual transmitting frequency could be 14.4 MHz, which is out of the amateur band. Checking with the built-in calibrator can insure that the circular dial is exactly on a 100 kHz point, but you cannot be sure which one it is on. Therefore, before transmitting, make sure you hear other amateur signals on both sides of your chosen frequency. If you do not, check your dial by turning the MAIN TUNING KNOB counterclockwise to the end of its travel. The circular dial should now be at the "500" end of its scale (refer to Detail 8-9B). If the calibration is correct for one band, it will be correct for the other bands.

INITIAL TUNE UP

The 10 steps of this procedure must be performed for all modes of operation.

1. Set the BAND switch and Main Tuning dial for the desired frequency.
2. Place the METER switch in the PLATE position.
3. Turn the MIC/CW LEVEL control fully counterclockwise.
4. With the RF load connected to the ANTENNA jack, set the MODE switch to TUNE. The meter should read 50 mA (at the ▼ mark).

If the meter needle indicates other than 50 mA, perform the BIAS adjustment described on Page 123 under Transmitter Alignment.

CAUTION: Do not turn on full output power continuously for more than 30 seconds at one time, or the final amplifier tubes or power supply may be damaged. Each time full output power is turned off, allow the tubes to cool for at least a minute.

Refer to Figure 1-19 for settings of the FINAL TUNE knob and lever.

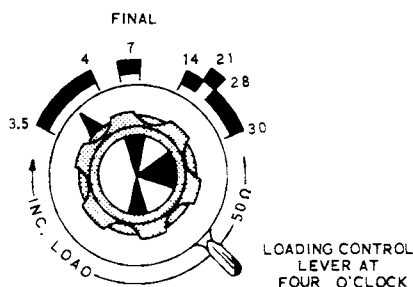

Figure 1-19

5. Set the METER switch to REL PWR and adjust the LOAD lever to the four o'clock position.
6. Set the FINAL TUNE knob to the position corresponding to the band in use.
7. Turn the MIC/CW LEVEL control clockwise to obtain a small up-scale indication on the meter. Then alternately adjust the PRESELECTOR, the FINAL TUNE knob, and the LOAD lever for a maximum indication on the meter.
8. Turn the MIC/CW LEVEL control clockwise until the meter reading no longer increases with knob rotation, and again peak the FINAL TUNE and FINAL LOAD controls for maximum output.
9. Set the METER switch to PLATE. The meter needle should read approximately 40 on the scale, indicating a plate current of 250 mA. (See "Reading the Meter," Page 139).
10. Return the MIC/CW LEVEL control to its full counterclockwise position.

CAUTION: The Transceiver should be retuned if the frequency is changed by any great amount. Be sure to readjust the FINAL TUNE controls. It may also be necessary to repeak the DRIVER PRESELECTOR control.

This completes the Initial Tune Up. Before placing the Transceiver in operation, complete either the following CW or Single Sideband adjustments.

CW OPERATION

For CW operation, the FUNCTION switch can be set to either the PTT or VOX positions. Even though CW operation is possible in the Calibrate position, it is not recommended because of possible spurious outputs from calibrator signals being present at the grid of the driver stage.

For 400 Hz CW selectivity, the Heath SBA-301-2 CW crystal filter may be installed in addition to the SSB crystal filter supplied with the Transceiver. The filter switch will then select the SSB or the CW filter.

Be sure steps 1 through 10 have been satisfactorily completed before proceeding with the following adjustments.

- () Place the MODE switch in the CW position.
- () Plug a key into the CW KEY jack.

The VOX DELAY control is located on the right side of the Transceiver.

- () While sending a series of "V's", adjust the VOX DELAY control so the relays stay energized between groups of characters. Clockwise rotation of this control will increase the holding time of the relays.

The final setting of the VOX DELAY control will be determined by the sending speed of the operator. The slower the sending speed, the higher the setting of this control. NOTE: Be sure the VOX DELAY control is adjusted so the relays do not open after each character is sent.

- () Set the MIC/CW LEVEL control to the minimum position that produces full output (increasing the control setting above this level DOES NOT increase the output or the REL PWR reading).

CROSS-MODE OPERATION

After the dial is set to zero beat the calibrator signal, the frequency of the CW output signal is 1000 Hz higher than the dial reading. The received signal is actually in the USB position even though the MODE switch is set at CW. Consequently, cross-mode operation is possible between USB and CW without any resetting of the MAIN TUNING dial. For example, if two stations begin operation in the USB mode of operation and one operator changes to CW, the other station will hear a 1000 Hz note without retuning his receiver. Also, the station operating in the CW mode will receive the USB signal from the other station without



changing back to the USB position of the MODE switch. When two stations are operating in the LSB mode and the operator of one changes to USB or CW, contact will be lost until the other station changes to either USB or CW.

SINGLE SIDEBAND OPERATION

Be sure steps 1 through 10 have been satisfactorily completed before proceeding with the following adjustments.

- () Set the MODE switch to either the USB or LSB position.
- () Connect a microphone to the MIC connector.
- () Set the METER switch to ALC (the meter needle may "rest" below zero in the Transmit mode).
- () Place the FUNCTION switch in the PTT position. (If your microphone does not have push-to-talk capabilities, make the VOX Adjustments and disregard PTT Adjustments).

PTT Adjustments

- () Actuate the transmitter and, while speaking into the microphone, turn the MIC/CW LEVEL control clockwise until the peak deflections register at about S3 on the meter. Keep the meter deflection below the S6 point on voice peaks for the most linear output.

Vox Adjustments

- () Turn the MIC/CW LEVEL control fully counterclockwise. Leave this control in this position for the following adjustments.
- () Set the FUNCTION switch to VOX.

NOTE: Close-talk into the microphone when using VOX operation to prevent background noise from tripping the Transceiver into transmit operation.

- () While speaking into the microphone, turn the VOX SENS control to just beyond a setting that will energize the relays. Be sure this control is not set so high that it will allow background noise to trip the relays.
- () Tune the receiver to a fairly strong signal and adjust the AF GAIN control for a comfortable listening level.
- () Place the microphone where it will normally be used. Advance the ANTI-TRIP gain control to just beyond a setting that will keep the speaker signal from tripping the VOX circuits. Be sure this control is not set so high that it completely disables the relay closing action.
- () Speak into the microphone and turn the VOX DELAY control to a setting that will hold the relays energized during the slight pauses between words. This prevents the relays from tripping at the beginning and end of each word.

NOTE: There will be a slight interaction between the VOX SENS, ANTI-TRIP, and VOX DELAY controls. Consequently, it may be necessary to readjust these controls to achieve the desired results.

The Transceiver is now ready for operation in the SSB mode. Speaking into the microphone (VOX) or using the microphone push-to-talk switch (PTT) will change the Transceiver from receive to transmit operation.

OPERATION WITH A LINEAR AMPLIFIER

Operation with a linear amplifier is similar to operation with an antenna at the output of the Transceiver, except that the linear amplifier input may have a different impedance. This will make it necessary to adjust the FINAL TUNE controls for maximum output (input to the linear amplifier). Figures 1-14 and 1-15 (on Page 132 and 133) shows the proper connections between a linear amplifier and the Transceiver.

SPECIFICATIONS

RECEIVER

Sensitivity	Less than .3 microvolt for 10 dB signal-plus-noise to noise ratio for SSB operation.
SSB Selectivity	2.1 kHz minimum at 6 dB down, 7 kHz ^{5 kHz} minimum at 60 dB down (3.395 MHz filter).
CW Selectivity (With Optional SBA-301-2 CW Filter Installed)	400 Hz minimum at 6 dB down, 2.0 kHz maximum at 60 dB down.
Power Output	2 watts with less than 10% distortion.
Spurious Response	Image and IF rejection better than 50 dB.

TRANSMITTER

DC Power Input	SSB: (A3J emission) 180 watt P.E.P. (normal voice, continuous duty cycle). CW: (A1 emission) 170 watts (50% duty cycle).
RF Power Output	100 watts on 80 through 15 meters; 80 watts on 10 meters (50 Ω nonreactive load).
Output Impedance	50 Ω to 75 Ω with less than 2:1 SWR.
Oscillator Feedthrough or Mixer Products	55 dB below rated output.
Harmonic Radiation	45 dB below rated output.
Transmit-Receive Operation	SSB: PTT or VOX. CW: Provided by operating VOX from a keyed tone, using grid-block keying.



CW Side-Tone	Internally switched to speaker to headphones, in CW mode. Approximately 1000 Hz tone.
Microphone Requirement	High impedance with a rating of -45 to -55 dB.
Carrier Suppression	45 dB down from single-tone output.
Unwanted Sideband Suppression	45 dB down from single-tone output at 1000 Hz reference.
Emissions not possible or not recommended	A0, A2, A3b, A4 through A9, F0 through F9, and P0 through P9.
Third Order Distortion	30 dB down from two-tone output.
RF Compression (TALC*)	10 dB or greater at .1 mA final grid current.

GENERAL

Frequency Coverage	3.5 to 4.0; 7.0 to 7.3; 14.0 to 14.5; 21.0 to 21.5; 28.0 to 28.5; 28.5 to 29.0; 29.0 to 29.5; 29.5 to 30.0 (megahertz).
Frequency Stability	Less than 100 Hertz per hour drift after 45 minutes warmup from normal ambient conditions. Less than 100 Hz for ±10% line voltage variations.
Modes of Operation	Selectable upper or lower sideband (suppressed carrier) and CW.
Dial Calibration	5 kHz divisions.
Calibration	100 kHz crystal.
Bandspread	35 -1/3 revolutions for 500 kHz.
Audio Frequency Response	350 to 2450 Hz.
Front Panel Controls	Main tuning dial. Driver Preselector. Final tuning. Final loading. Mic and CW Level control. Mode switch. Band switch. Function switch. Meter switch. RF Gain control. Audio Gain control. Filter selector switch.

*Triple Action Level Control™.

Side Controls	Meter Zero control. Bias Adjust. VOX Sensitivity. VOX Delay. Anti-Trip.
Internal Controls	Carrier Null (control and capacitor). Neutralizing. Crystal calibrator. VFO trimmer. VFO shifter. VFO coil.
Tube Complement	OA2 Regulator (150 V). 6HS6 RF amplifier. 6HS6 1st receiver mixer. 6AU6 Isolation amplifier. 6AU6 1st IF amplifier. 6AU6 2nd IF amplifier. 6BN8 Product detector and AVC. 6AU6 VFO Amplifier. 6CB6 2nd transmitter mixer. 6CL6 Driver. 6EA8 Speech Amplifier and cathode follower. 6EA8 1st transmitter mixer. 6EA8 2nd receiver mixer and relay amplifier. 6EA8 CW side-tone oscillator and amplifier. 6GW8 Audio amplifier and audio output. 12AT7 Heterodyne oscillator and cathode follower. 12AT7 VOX amplifier and calibrator oscillator. 12AU7 Sideband oscillator. 6146 Final amplifiers (2).
Diode Complement	6 Germanium Diodes: Balanced modulator, RF sampling, and crystal calibrator harmonic generator. 9 Silicon Diodes: ALC rectifiers, anti-trip rectifiers, and DC blocking. 1 Zener Diode: cathode bias.
Transistors	MPF-105 FET-VFO. 2N3393 Voltage regulator.
Rear Apron Connectors	CW Key. 8 Ω output. ALC input. Power and accessory plug. Antenna. Spare.
Power Requirements	700 to 850 volts at 250 mA with 1% maximum ripple. 300 volts at 150 mA with .05% maximum ripple. -115 volts at 10 mA with .5% maximum ripple. 12 volts ac/dc at 4.76 amps.



Cabinet Dimensions	14-13/16" wide x 6-5/16" high x 13-3/8" deep.
Net Weight	17-1/2 lbs.
Equipment Used to Prepare Specifications	Heath HN-31 "Antenna," Heath SB-610 Monitor Scope. Heath IM-11 VTVM. Heath MM-1 VOM. Heath IG-72 Audio Generator. Heath HDP-21 A Microphone. Hewlett-Packard Electronic Counter, Model 5246L. Tektronix Oscilloscope, Model 581 A. Hewlett-Packard Signal Generator, Model 606A. Panoramic Radio Products Inc., "Panalyzer," Model SB-12A. Boonton RF Voltmeter, Model 91-CA. Dynascan Digital Voltmeter, Model 111.

The Heath Company reserves the right to discontinue instruments and to change specifications at any time without incurring any obligation to incorporate new features in instruments previously sold.

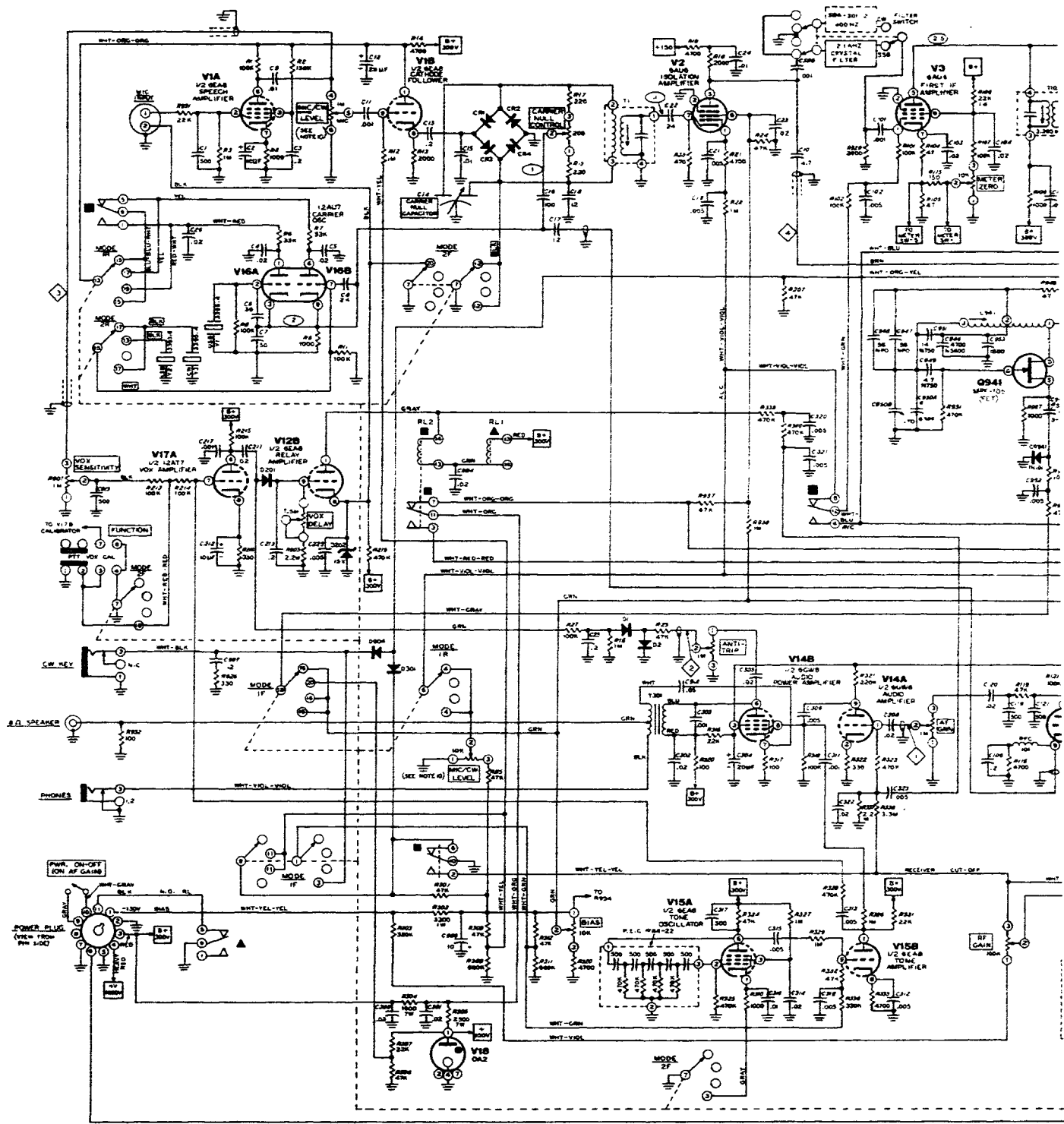

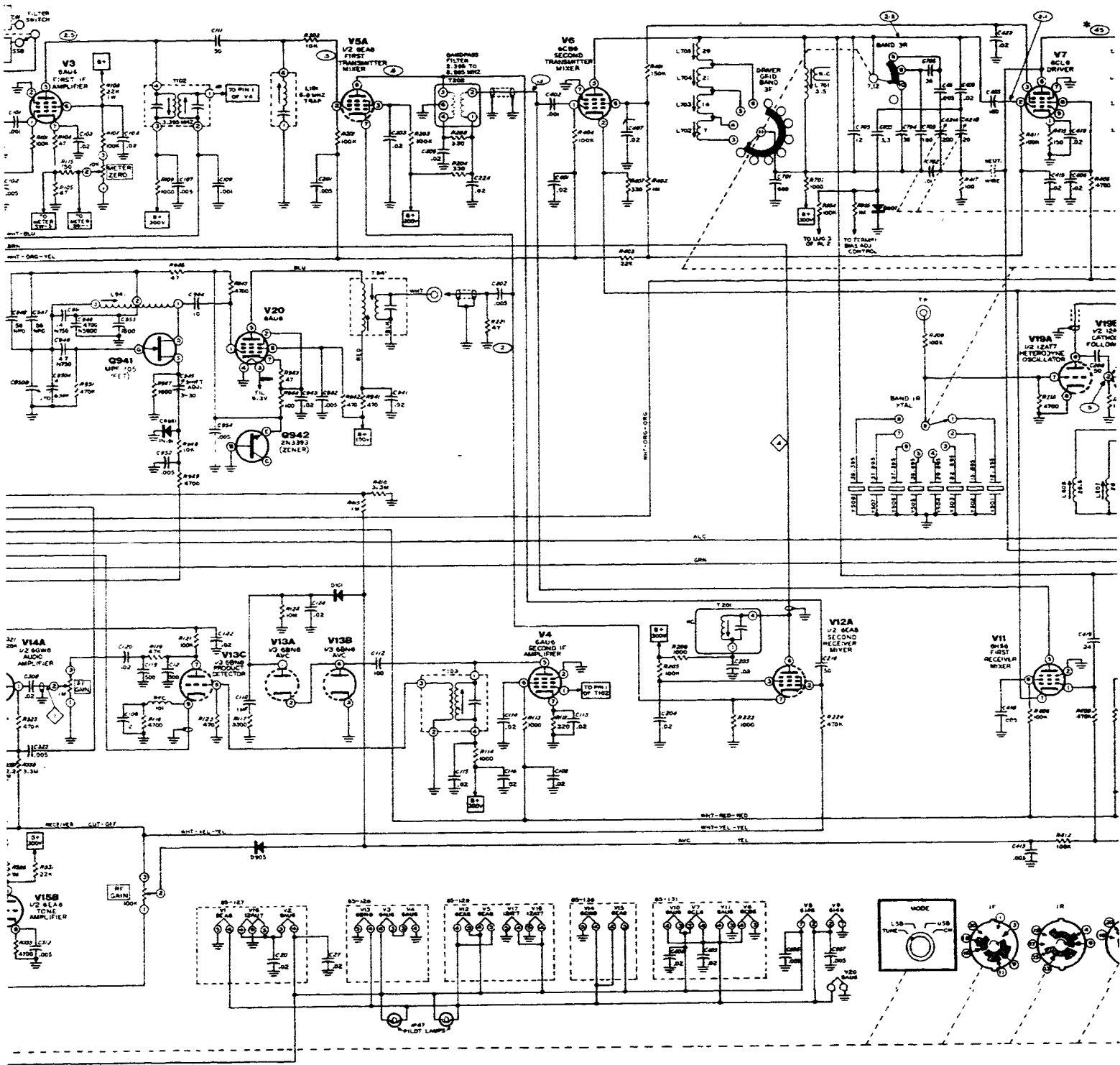

SCHEMATIC OF THE
HEATHKIT®
SSB TRANSCEIVER
MODEL HW-101

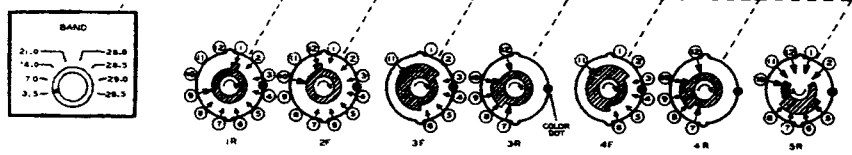
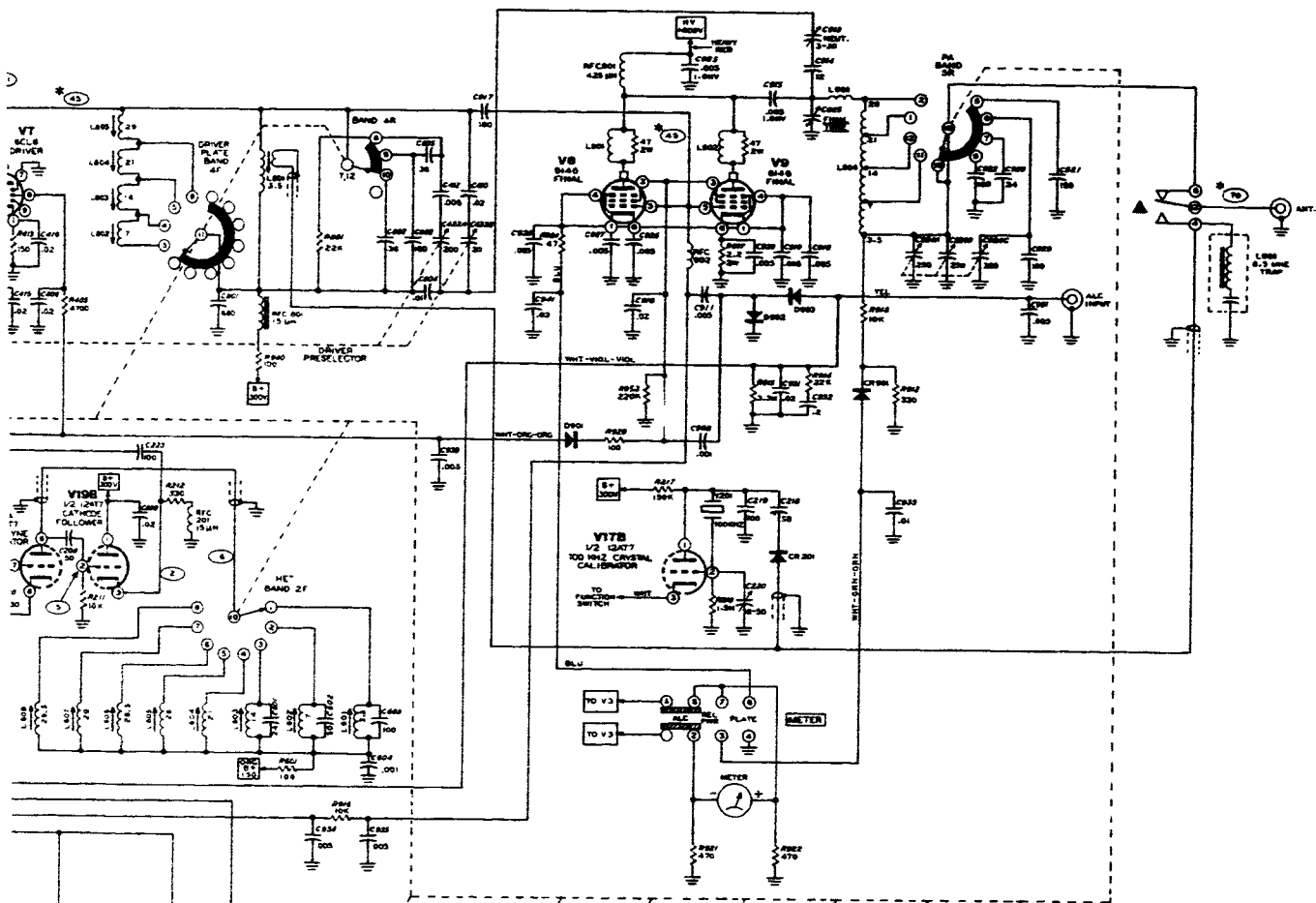

NOTES:

LETTER-NUMBER DESIGNATIONS FOR RESISTORS, CAPACITORS, ETC., HAVE BEEN PLACED IN THE FOLLOWING GROUPS:

- 0-99 PARTS ON MODULATOR CIRCUIT BOARD.
- 100-199 IF
- 200-299 BANDPASS
- 300-399 AUDIO
- 400-499 RF DRIVER
- 500-599 CRYSTAL
- 600-699 HETERODYNE
- 700-799 OSCILLATOR
- 800-899 DRIVER GRID
- 900-999 DRIVER PLATE
- 000-999 PARTS MOUNTED ON THE CHASSIS.

1. ALL RESISTORS ARE 1/2 WATT UNLESS MARKED OTHERWISE. ALL RESISTOR VALUES ARE IN OHMS (K = 1000, M = 1,000,000).
2. UNLESS OTHERWISE MARKED, ALL CAPACITOR VALUES OF 1 OR OVER ARE IN μ F, AND ALL VALUES LESS THAN 1 ARE IN μ F.
3. REFER TO THE X-RAY AND CHASSIS VIEWS FOR PHYSICAL LOCATION OF PARTS.
4. SEE THE VOLTAGE CHARTS AND THE RESISTANCE CHART FOR ALL MEASUREMENTS.
5. ALL SWITCHES ARE IN THE POSITION INDICATED BY THE CROSS POINTERS.
6. ARROW (\curvearrowright) INDICATES CLOCKWISE ROTATION OF KNOB (VIEWED FROM KNOB END).

7. \diamond NUMBERED COAXIAL CABLE.
8. \circ INDICATES RF VOLTAGE WITH CONTROLS SET PER FIGURE 1-21.
9. ALL RELAY CONTACTS SHOWN IN TRANSMIT (TUNE) POSITION.
10. MIC/CW LEVEL IS A DUAL CONTROL.
11. FOR GREATER CLARITY, RELAY SECTIONS ARE SHOWN CLOSEST TO THE CIRCUITS IN WHICH THEY ARE USED. ONE OF THE FOLLOWING MARKS IS USED TO IDENTIFY THE SEPARATED SECTION OF THE RELAY:
 - \triangle = PART OF RELAY RL1
 - \square = PART OF RELAY RL2

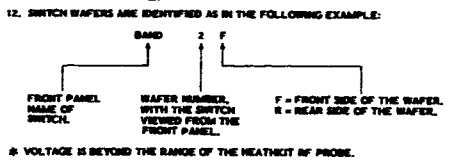

* VOLTAGE IS BEYOND THE RANGE OF THE HEATHKIT RF PROBE.

DIODES		
COMPONENT DESIGNATION	TYPE	HEATH PART NO.
D 1, 2, 101, 201, 301, 902, 903, 904, 905, 906	1N2071 (1 A, 600 PRV)	57-27
D901	1N4140	56-56
CR 1, 2, 3, 4, 201, 901, 941	1N191	56-26-1
D 202	15 V. Zener	56-25

TRANSISTORS			
COMPONENT DESIGNATION	HEATH PART NO.	MANUFACTURER'S NUMBER	(BOTTOM VIEW) BASING
Q941	417-109	MPF-105 FET	
Q942	417-118	2N3053	